

# Technical Data Sheet

Product:	C15 range
Version:	3.5
Page	1 of 6

## General Description

The Rotrex C15 centrifugal supercharger is the most compact supercharger available. Covering the range of engines up to 2 litres producing up to about 200hp - the C15 is the perfect choice for small engine applications such as compact cars, motorcycle engines, snowmobiles, quads etc.

Through the patented hi-speed planetary traction drive, the C15 achieves impeller speeds of up to 201,500rpm for the 16 trim and 150,000rpm for the 60 trim. The exceptional high speeds of the drive give an unsurpassed power to size ratio compared to any other supercharger on the market.

The very low noise and vibration characteristic as well as the high efficiency of these superchargers set the industry standard for what is achievable.

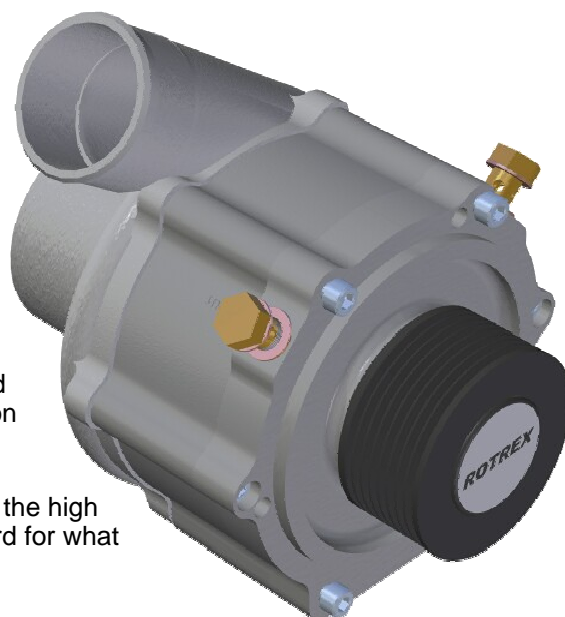

## Applications

The C15 range of superchargers is designed for four stroke gasoline engines. However two stroke engines or even diesel engines can benefit from these superchargers with remarkable results. Depending on the application the C15 will support engine outputs from less than 30hp to more than 200hp. Combining two C15 superchargers on one engine will make it possible to reach very high power levels in a vehicle where packaging and space will not allow traditional supercharging with a single large supercharger.

The groundbreaking compact size enables a very flexible supercharger installation particularly on engine applications where optimum efficiency as well as weight and size are essential.

The supercharger is driven by a 7 or 8 ribbed poly V-belt depending on pulley choice. The 7 ribbed pulleys are available in aluminium and the material of the 8 ribbed versions is high strength steel. Pulley diameter ranges from 70 to 90mm in 5mm steps.

The compressor housing can be rotated freely in 60 degree intervals to allow easy adoption to any application.

## Oil system

The supercharger features an integrated dual-action oil pump, which functions as oil supply pump as well as a dry sump-scavenging pump. An external oil reservoir, filter and optional cooler are supplied with the supercharger. The self-contained oil system allows free positioning of the supercharger on the vehicle, and has the benefit of adding the supercharger without worrying about tampering with the oil system of the engine or any other accessory.

The requirement for oil cooling will depend on the individual application. In special cases where natural cooling of the aluminium canister and oil lines is sufficient the installation can be carried out without a dedicated oil cooler. The standard oil set has all the necessary hoses, fittings, canister and cooler.

The Rotrex SX100 supercharger traction fluid has been developed for optimum lubrication, cooling and traction capabilities under extreme conditions. Always use SX100 traction fluid with your C-type Rotrex supercharger.

# Technical Data Sheet

Product:	C15 range
Version:	3.5
Page	2 of 6

## Characteristics

Characteristic	Symbol	C15-16	C15-60
Power range <sup>1</sup>	$P_{\text{range}}$	30-130 Hp	50-200 Hp
Max mass flow rate	$M_{\text{flow}}$	0.11 kg/s	0.18 kg/s
Drive unit ratio	N	1:12.67	
Drive efficiency	$\eta$	96%	
Pulley sizes available	$\varnothing_{\text{pulley}}$	70, 75, 80, 85, 90mm 7 rib aluminium or 8 rib steel - PK profile	
Unit weight	M	2.9 Kg (6.4 lbs)	
Rotational direction	$R_{\text{in direction}}$	Clockwise rotation, as seen from pulley side	
Peak input shaft speed	$R_{\text{in max}}$	15,900 rpm	11,840 rpm
Peak impeller speed	$R_{\text{out max}}$	201,500 rpm	150,000 rpm
Min inlet oil temperature	$T_{\text{oil, in min}}$	-40°C (-40°F)	
Max inlet oil temperature	$T_{\text{oil, in max}}$	+80°C (176°F)	
Mounting torque Pulley bolt	M10	50Nm (37 ft-lb)	
Mounting torque Bracket bolts	M5x60	4.5Nm (3.3 ft-lb)	
Mounting torque Oil banjo bolts	M10x1	21Nm (15.5 ft-lb)	

<sup>1</sup> Power output is dependent on engine type, cooling, cam-timing etc.

### Conversion Toolbox

Temperature conversion

$$^{\circ}\text{C} = \frac{5}{9} \times (^{\circ}\text{F} - 32) \quad \text{OR} \quad ^{\circ}\text{F} = \frac{9}{5} \times ^{\circ}\text{C} + 32$$

Kg/s to CFM conversion

$$\text{CFM} = \frac{\text{kg}}{\text{s}} \times 1731.8 \quad @ 15^{\circ}\text{C and } 0.1013\text{MPa}$$

# Technical Data Sheet

Product:	C15 range
Version:	3.5
Page	3 of 6

## Flow chart C15-16

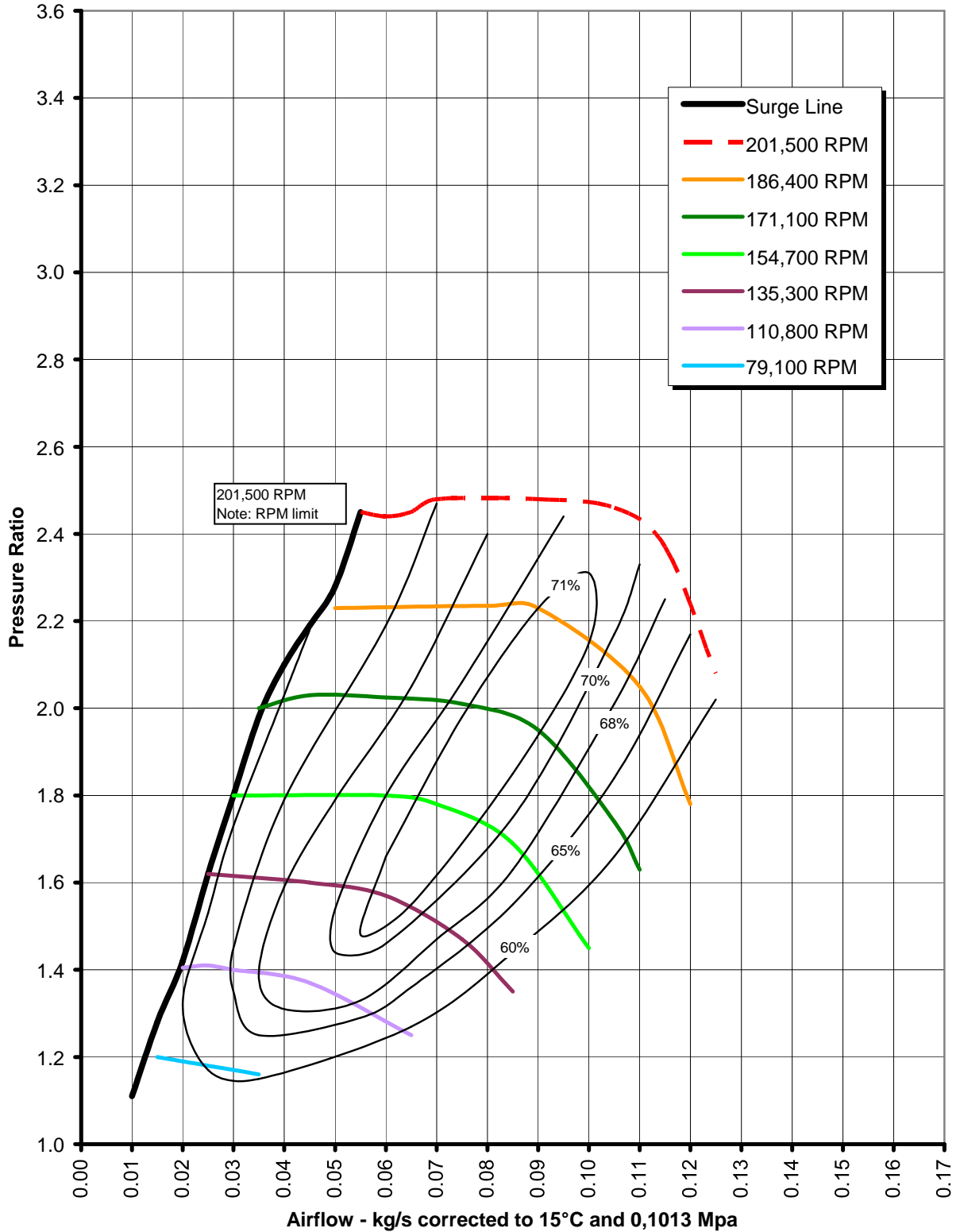

# Technical Data Sheet

Product:	C15 range
Version:	3.5
Page	4 of 6

## Flow chart C15-60

